

# I.P. APPLICATION NOTES



The new VOIP and IP series of Chiron's successful communications processors offers new opportunities in protocol conversion. Now Chiron offers the opportunity of using the existing Proteus Interfaces with IP (Internet Protocol) networks to build a wide range of voice and data IP products.

The New IP series of Proteus can be used either to build new voice and data products for IP networks or in converting legacy product for a cost efficient upgrade to the new networks. In fact with the multiple paths open to the Proteus structure, this new series of processors is ideal in designing back-up routing products.

In having a full range of TCP/IP; VOIP as well as data capabilities and inbuilt Codec, the new Proteus versions are ideal in applications where existing data systems cannot support TCP/IP such as small 8 bit micros, whereby Proteus can offer a cost effective upgrade path. In having a full POTS telephony capability Proteus can also offer an upgrade path for any Telephony product.

As with all the Proteus range, the options are vast and only limited by the imagination. If the configuration is not part of our standard range, then please ask and Chiron will consider building a configuration to your needs. Some of the examples that the new Proteus IP products can be used in are:-

## **Telephony**

- VOIP Telephones
- PBX Line Cards for IP networks
- Enhancing legacy PBX's to operate over IP Networks

## **Retail & Finance**

- Credit Card terminals
- ATM Systems

## **Telemetry**

- Metering
- Conversion of any product with a serial interface or modem

## **Security**

- Polling of Alarm panels
- Carrying Alarm alerts
- Video surveillance
- Dual alerting and dialling paths

These are only a few of the examples of the new IP series of Proteus from Chiron.

***Given the flexibility of Proteus for IP the options are as varied as your applications and imagination.***

Below we outline only some of the potential configurations and product options.



Chiron Technology Ltd  
Wyvols Court  
Swallowfield, Reading  
Berkshire RG2 1WY  
Tel +44 (0)118 988 0228  
Fax +44 (0)118 988 1055  
E-mail sales@chiron.uk.com  
Web www.chiron.uk.com

# TELEPHONY OVER IP

## VOIP Telephones.

With full Q931 signalling control and inbuilt Codec, the Proteus is the ideal heart of an IP telephone. Proteus II can handle all of the following:-

- G.711 compatible Codec with A-law coding
- On-off hook detection
- DTMF tone recognition
- Ring signal generation controller
- Drivers for hook state and call state indication
- CLI presentation on voice/POTS pots with FSK
- Auto-dial and auto-answer
- Calling number (CLI) validation on incoming calls
- Direct Handling of MMI functions including
  - LCD Display
  - Phone Book
  - Missed Calls
  - Last Calls Made
  - Etc.

With Chiron's unique API, Proteus offers all of these functions in one single processor with a minimum of external components.

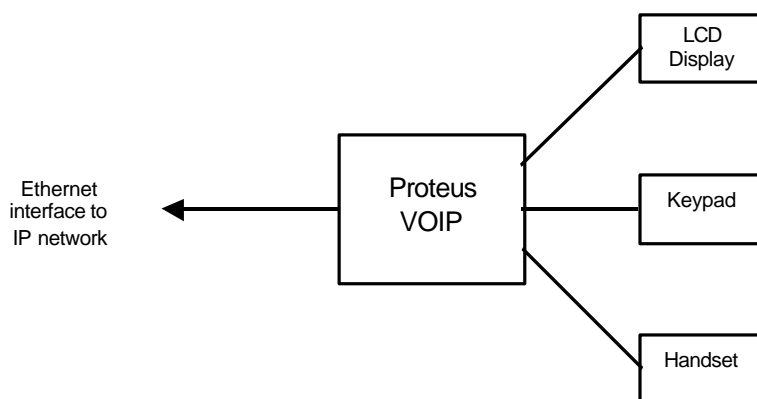

In fact versions of Proteus are available that offer extra functions that make a Proteus VOIP Telephone completely unique. Some of the options are:-

**External POTS Port** :- It is possible to build a VOIP telephone with a built in POTS port to support legacy products such as Answer phones and Fax's at marginal cast as everything is handled within Proteus.

**Configuration updating across the network**:- With an inbuilt data capability an IP telephone built around Proteus can have their configurations and phone book updated from a PC across the network. For example it would be easy to synchronise the phone book with the users Outlook database on his PC.

*Proteus II is a truly single processor option for your VOIP Handset.*

## PBX Line Cards for IP networks

With the growth of services such as ADSL many PBX's will in the near future will be looking towards new IP interfaces and Line Cards to make them compatible with the new networks. With the ability of converting within Proteus from G714 or analogue, Proteus can interface at the ISDN, analogue or PCM level to the Backplane of a PBX, making it an ideal for new Line cards

## Enhancing legacy PBX's to operate over IP Networks

Chiron's new Connect range of products using Proteus IP series processors allow a quick and cost effective means of upgrading legacy PBX's to operate across the new networks. The connect 600 range offers a quick and efficient means of upgrading legacy PBX's to IP networks, by interfacing to existing analogue or ISDN trunks.

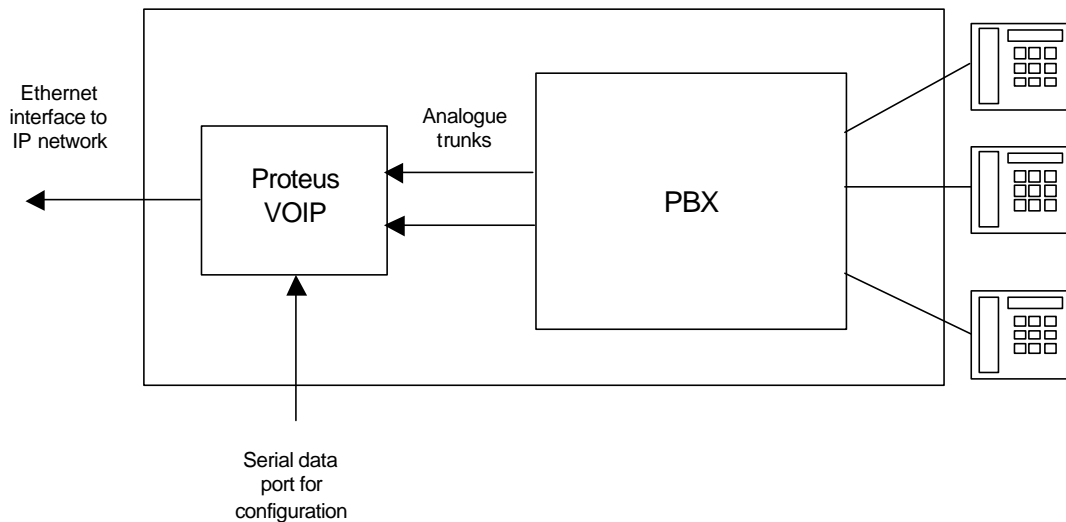

Updating of the routing tables and conversion of the PSTN Number to IP equivalent can be undertaken either via the serial Port on the unit or remotely across the network.

## 2. TELEMETRY AND FINANCIAL APPLICATIONS.

Many existing products are constructed with simple serial data ports and designed for modems or direct connection using point-point serial cables. As such they are not always easy to convert to IP protocols. In fact many such products do not have the processing power or memory capacity to run TCP/IP protocols on top of their native applications. Proteus II offers the opportunity to quickly convert the products by taking the serial interface and undertaking all of the network interfacing, TCP/IP protocol conversion, call handling and data buffering within the Proteus.

The Proteus Series for IP has the following advantages:-

- Modem look-and-feel Hayes interface for straightforward modem replacement
- Auto-dial mode for 'virtual serial cable' applications
- Updating of existing system to IP networking with the minimum of engineering effort
- Inbuilt IP 'Ping' support for polling to regularly check unit and communications integrity
- Audio can also be added, e.g. for credit card voice referrals

Proteus will even buffer the IP messages and undertake rate adaption between the IP network and the application processor.

In this configuration Proteus can be used to convert a variety of applications from metering to vending machines, credit card terminals, ATMs etc..

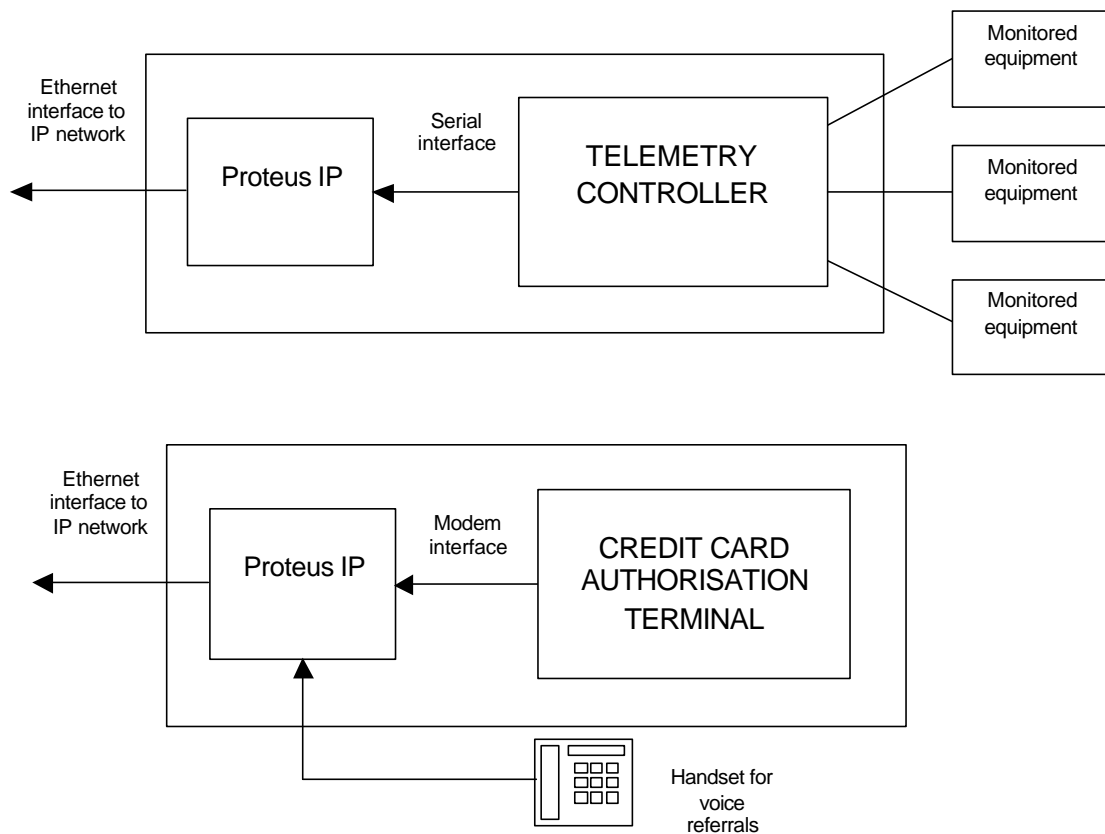

### 3. SECURITY APPLICATIONS

The Security Industry has special requirements covering Polling; Alarm Alerts; Voice; as well as Video Surveillance. IP networks are an ideal and cost effective format for all of these requirements.

Proteus from Chiron is available as a range of processors for the Security industry as well as in pre-configured PCB's. These products will allow the following features:-

- Cost effective continual polling of the line and alarm panel
- Alarm alerts to be carried over IP, either as Modem replacement or DTMF codes.
- Video Surveillance at the capacity of the network which can often be of greater quality than ISDN.
- Voice and Audio verification
- Access control systems

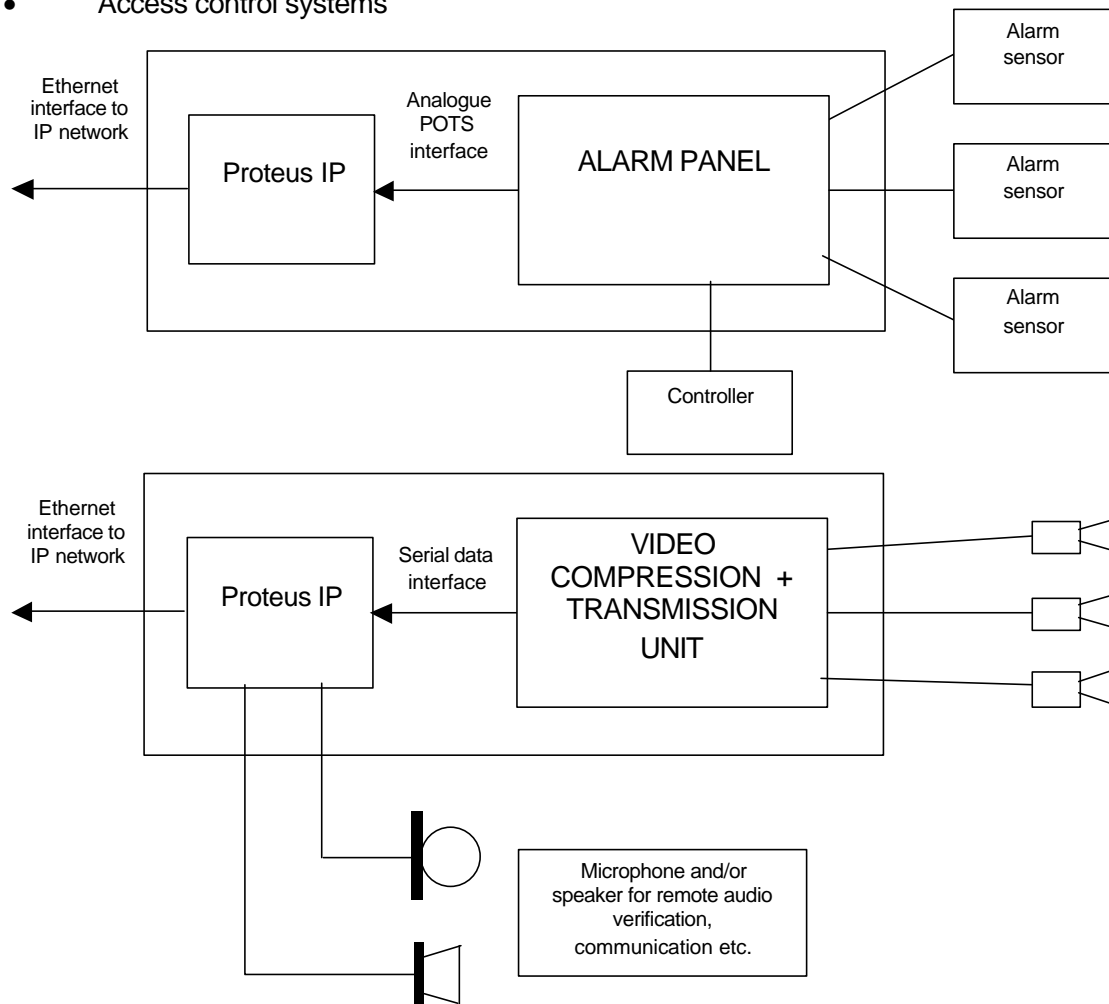

For the security Industry the IP Series of Proteus Processors can also be combined with other interfaces to offer Dual Dialling paths for systems resilience. For example IP can be combined with ISDN or GPRS backup.